

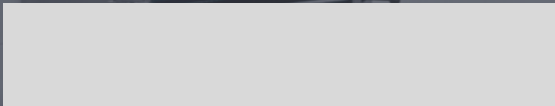

FOOD SERVICE EQUIPMENT



LET'S CHAT

Have Equipment needs? Contact your Food Service Rep to learn more about our line of kitchen equipment and deals. For pricing, please contact Heather Means at hmeans@merchants-grocery.com



Steel Work Tables



Refrigerated Prep Tables



Hot Food Merchandisers

CONTACT

MERCHANTS-GROCERY.COM  877-897-9893 

STEEL WORK TABLE



#60047 24"X24"X34"

ALL STAINLESS STEEL WORKTABLE- 4 LEGS



#60000 24"X48"X34"

ALL STAINLESS STEEL WORKTABLE- 4 LEGS



#60001 24"X96"X34"

ALL STAINLESS STEEL WORKTABLE- 6 LEGS



- 20 GAUGE 430 STAINLESS STEEL
- INCLUDE 20-GAUGE 430 STAINLESS STEEL UNDERSHELF, HAT CHANNEL, LEG, SOCKET AND BULLET FOOT
- EASY INSTALLATION
- EASY TO CLEAN

REFRIGERATED PREP WORK TABLE

WITH THREE DOORS



#60049

70" REFRIGERATED PREP TABLE WITH 3 DOORS



- STAINLESS STEEL EXTERIOR & INTERIOR
 - REMOVABLE DOOR GASKET
 - 10 MM CUTTING BOARD THICKNESS
- ADJUSTABLE HEAVY-DUTY PVC COATED SHELVES
 - SELF-CLOSING DOORS
- HEAVY-DUTY CASTERS WITH BRAKES
- DIGITAL TEMPERATURE CONTROLLER

HOT FOOD MERCHANDISER



#60043

47" HOT FOOD MERCHANDISER

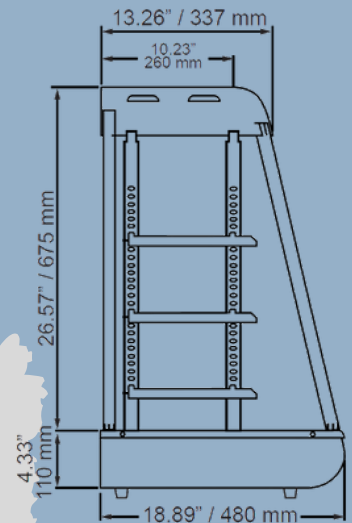
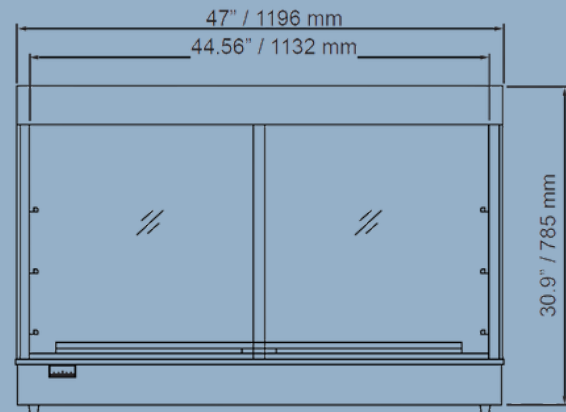
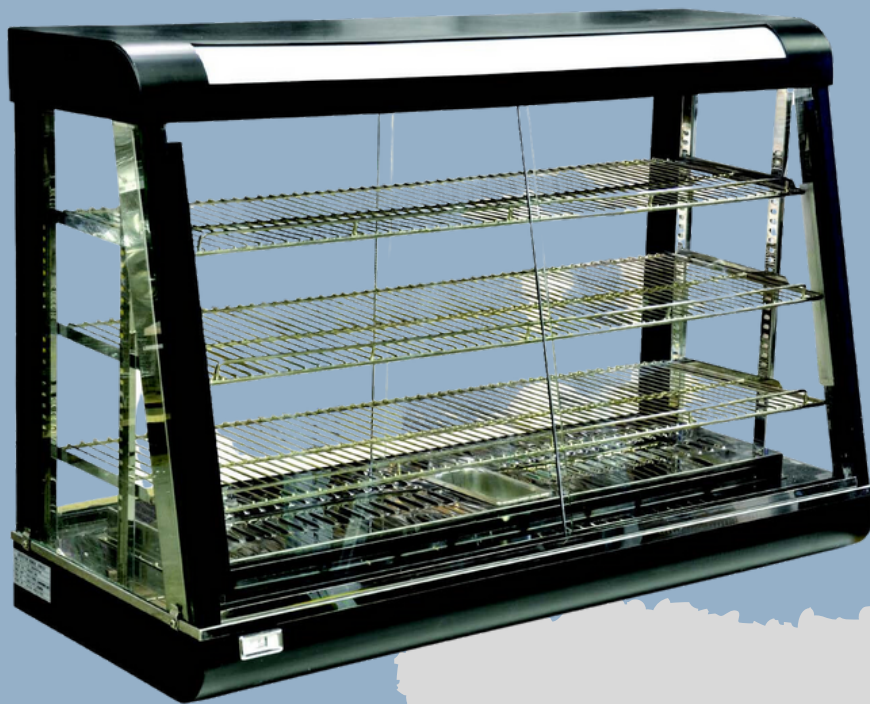

- DESIGNED WITH ADJUSTABLE TRAYS AND GLASS ON ALL SIDES
- EQUIPPED WITH A THERMOSTAT MONITOR FOR CONSISTENT TEMPERATURES
- WATER TRAY INCLUDED TO ADD HUMIDITY TO THE CABINET
- OPENS FRONT AND BACK